

An Agenda-Setting Model of Electoral Competition

Josep M. Colomer¹ and Humberto Llavador²

November 2008

Abstract

This paper presents a model of electoral competition focusing on the formation of the public agenda. An incumbent government and a challenger party in opposition compete in elections by choosing the issues that will key out their campaigns. Giving salience to an issue implies proposing an innovative policy proposal, alternative to the status-quo. Parties trade off the issues with high salience in voters' concerns and those with broad consensus on some alternative policy proposal. Each party expects a higher probability of victory if the issue it chooses becomes salient in the voters' decision. But remarkably, the issues which are considered the most important ones by a majority of votes may not be given salience during the electoral campaign. An incumbent government may survive in spite of its bad policy performance if there is no sufficiently broad consensus on a policy alternative. We illustrate the analytical potential of the model with the case of the United States presidential election in 2004.

¹ Institute of Economic Analysis (CSIC) and Universitat Pompeu Fabra. josep.colomer@gmail.com

² Universitat Pompeu Fabra and Barcelona GSE. humberto.llavador@gmail.com

The authors acknowledge financial support from the Spanish Ministry of Science, Research project SEJ2006-10974.

1. Introduction

On the occasion of the United States presidential election in 2004, former president Bill Clinton, who was not running as candidate, stated: “Generally, the presidential elections in the United States turn always around three questions. First: how one would feel at having that person as president?... As second element there is the candidate's position on certain issues. The third factor is the following: What is this election about? Is it about the United States having a multilateral attitude in foreign policy? Or is it whether taxes should be lowered for the rich or more should be done for the poor?”

In this paper we focus on the third factor: what elections are about. Just to mention an illustration of the relevance of the selection of issues during the electoral campaign, let us also quote somebody involved in the November 4th, 2008 U.S. presidential election. This was published at the beginning of September, just after the two party conventions, when the survey polls showed a close tie between the two main candidates: “‘If in October we’re talking about Russia and national defense and who can manage America in a difficult world, John McCain will be president’, predict[ed] Thomas Rath, the leading Republican strategist in the swing state of New Hampshire. ‘If we’re talking largely about domestic issues and health care, Barack Obama probably will be president’. Events can affect that conversation. If Russia invades another country on Oct. 20 or Iran detonates a nuclear weapon, advantage McCain; if there’s another Bear Stearns meltdown, or a stock market crash, put a few points on the Obama side.” (Albert R. Hunt, ‘Letter from Washington’, *New York Times*, Sep. 8th, 2008). Indeed, one month later, during the third Presidential Debate in October 15th,

Barak Obama pointed out that “Senator McCain’s own campaign said publicly last week that, if we keep on talking about the economic crisis, we lose, so we need to change the subject.”

This paper discusses the criteria for party choices of issues and the subsequent campaign outcomes. We present a formal model of electoral competition focusing on the formation of the public agenda, in which political parties or candidates compete to win an election by choosing an issue and a policy position on that issue to which they try to give political salience. Giving salience to an issue implies proposing an innovative policy proposal on the issue as an alternative to the status-quo policy, as well as talking about it, usually with a value or argument, and making it news with some effort investment in order to making it relevant for voters’ electoral decisions.

A party will choose a priority issue to campaign for if it is a likely winning issue, that is, it has a likely winning position and it is likely to become decisive in the election. Whether an issue will become a winning issue depends on two variables: (i) the ex-ante ‘*pre-campaign or social salience*’ of the issue in voters’ concerns and (ii) the voters’ support or ‘*consensus*’ in favor of an alternative policy proposal on the issue.

Thus, parties have to trade off the two variables. If one issue is highly salient in the voters’ concerns, but voters are highly divided about which one of the possible policy alternatives to the status-quo is better, choosing to campaign on the issue by holding one of the policy alternatives may be risky. If, on the contrary, there is broad social consensus about the best policy alternative to the status-quo on one issue, but the issue is not a priority for voters’ electoral decision, running on that issue can attract little attention.

Hence, whether parties compete by raising the same issue and proposing two different policy alternatives on it or by choosing different issues does not depend only on voters’ priority concerns, but also on each party’s likelihood to hold potentially

winning policy positions. It is always possible that the issues which are considered the most important ones by a majority of voters be not given political salience by parties during the electoral campaign. As a consequence, mediocre policies broadly rejected by the electorate, as well as incumbent parties with no good performance in government, may survive.

Foundational works about the importance of agenda-setting in competitive elections include the well-known contributions by Stokes (1963) and Petrocik (1996). They depart in important aspects from the standard ‘spatial theory’ of electoral competition, in which parties or candidates compete by choosing policy ‘positions’ on a space which is basically given. (See the critical review of the literature by Colomer and Puglisi (2005). However, not a formal model had been elaborated, to our knowledge, which specifies the structural and strategic conditions in which political parties or candidates choose issues in the electoral campaign and shape the relevant policy space. We discuss these conditions and analyze the type of issues --as defined for their salience in voters’ concerns and the acceptance of policy proposals on them— which should be expected to be chosen in equilibrium.

To give some realistic support to this discussion, let us consider a couple of examples. When, after World War II, the British labour party in government introduced a general system of social security, including universal health care, unemployment benefits, pensions for the elderly and other safety nets, this was a very innovative policy. It quickly won the support of wide layers of the society, thus inducing the conservatives to adapt to that policy. Policy consensus on the issue existed for several decades, in Britain as in many other countries following similar experiences. But the labour or the social-democratic parties were, generally, more broadly trusted by the public interested in the issue than the conservative ones and, thus, they tended to emphasize this issue in their electoral manifestos and campaigns.

In another instance, the policy of balanced budgets, that is, to equate the public revenues with expenditure over the business cycle, was very innovative when it began to be introduced in the United States in the 1980s. Later on, in light of its effects for reducing inflation, the policy of near-balanced budgets was adopted by the European Union, as well as by the International Monetary Fund for low-income countries. Policy consensus was broadly diffused. But, in this case, it worked on the political advantage of the conservatives.

Similar stories could be told for different places and moments regarding once innovative policies, such as civil rights for ethnic minorities, transnational free trade, women's equal rights, re-privatization of state-owned industries producing private goods, suppression of the compulsory military service, international justice for crimes against humanity, etc. None of these proposals were initially intermediate compromises between distant alternative policies, but were highly innovative when they were launched by some leader, group or party for the first time. However, policy consensus was eventually built on these and other issues after some success. (For empirical data on issues in electoral platforms, see Riker (1993), Budge (1993), Budge et al. (2001), Petrocik, Benoit and Hansen (2002), Klingemann et al. (2006).)

The plan for the rest of the paper is the following. In section 2 we present a spatial model of agenda formation in which parties compete on one issue at a time. For each issue there is some probability of victory for the party holding the most popular policy alternative. We introduce the concepts of issue salience and the degree of consensus. Section 3 presents equilibrium results. Section 4 provides several examples showing that parties can compete on issues with either high salience or broad consensus or both. They do not compete, in equilibrium, on issues with both low salience among voters and low consensus regarding the best policy alternative. However, parties may choose not to campaign on those issues with highest salience in voters' concerns, thus

postponing solutions to unpopular status-quo policies with considerable social discontent. In section 5, as an illustration, we discuss the choice of campaign issues for the 2004 United States presidential election in the light of the findings in the model. Section 6 concludes.

2. The Model

Consider an incumbent party in government (G) and a challenger party in opposition (O) that compete to win an election by choosing an issue and a policy position on that issue. There are N potential issues, and for each issue $i = 1, \dots, N$, there exists a status-quo policy (q_i) and two innovative policy proposals located *on different sides* of q_i , which can be called x_i and y_i respectively. If the issue is, for example, taxes, one of the alternatives implies higher taxes, and the other lower taxes, than the status-quo, and similarly for any other issue, so that the two alternatives are *on different sides* of the status-quo. That is, either $x_i < q_i < y_i$ or $y_i < q_i < x_i$. Denote by $A_i = \{x_i, q_i, y_i\}$ the set alternatives on issue i .³

2.1. Electorate

Voters have convex preferences over the feasible set of policy alternatives and vote accordingly. For an issue i , let $\mathbf{F}_i(a_i, a'_i)$ be the fraction of citizens who prefer alternative a_i to a'_i , keeping all other issues constant at the status-quo. Denote by $\mathbf{F}_i^x = \mathbf{F}_i(x_i, q_i)$ and by $\mathbf{F}_i^y = \mathbf{F}_i(y_i, q_i)$ the support for each one of the alternatives against

³ We only require that the possible positions on each issue are clearly distinct on each other and that there is at least one position on each side of the status-quo for each issue. The main results from this three-alternative model would continue to hold in a framework where each issue admits a finite number of distinct positions. Therefore, we side with Polborn and Krasa (2007) is arguing that “a setup with very few feasible positions on each issue is actually a quite realistic description of political campaigns” (p.2).

the status-quo. For simplicity, assume that $\mathbf{F}_i^x \neq \mathbf{F}_i^y$ and re-label the alternatives to the status-quo so that x_i represents the one with the higher support, $\mathbf{F}_i^x > \mathbf{F}_i^y$.

The assumption that innovative policy proposals are on different sides of the status-quo implies, by the convexity of preferences, that voters who favor alternative a_i prefer the status-quo to the other alternative a'_i . Formally, preferences satisfy that, fixing the policy on all other issues, if $x_i \succ q_i$ then $q_i \succ y_i$. And similarly, if $y_i \succ q_i$, then $q_i \succ x_i$.⁴ Intuitively, this means, for example, that voters who would like lower taxes would vote against a tax increase by supporting the status-quo.

2.2. The probability of winning on an issue

The winning alternative on a particular issue i is the one receiving a majority of votes. There is uncertainty on the outcome of the election so that no alternative wins with probability one.

Definition 1. Let $\pi_i : A_i \times A_i \rightarrow (0,1)$ be the *probability of victory on issue i* function, with $\pi_i(a_i, a'_i)$ representing the probability of victory of a_i against a'_i .

Letting $\pi_i^x = \pi_i(x_i, q_i)$ and $\pi_i^y = \pi_i(y_i, q_i)$ represent the probabilities that alternatives x_i and y_i defeat the status-quo on issue i , we take their probability of winning to be increasing in the fraction of supporters: $\pi_i^x = \phi_i(F_i^x)$ and $\pi_i^y = \phi_i(F_i^y)$, with $\phi' > 0$. We also assume that $\phi_i(1/2) = 1/2$.⁵

Because $\mathbf{F}_i^x > \mathbf{F}_i^y$, it follows that $\pi_i^x > \pi_i^y$, that is x_i is the advantaged alternative on

⁴ For the present analysis we only require that the previous conditions on induced preferences hold when all other issues are fixed at the status-quo. Hence, convexity of preferences is a stronger assumption than needed.

⁵ None of the qualitative results hinges on this assumption that we make to simplify the exposition.

issue i . Without loss of generality, we can sort the issues $i = 1, \dots, N$ according to the probability of victory of the advantaged alternative. We assume for simplicity a strict ordering:

$$\pi_1^x > \pi_2^x > \dots > \pi_{N-1}^x > \pi_N^x. \quad (1)$$

In order to shape the conditions of the electoral competition, we assume that a party cannot win by proposing an alternative already claimed by the other party. This implies that a party proposing a policy alternative on one issue forces the other party to defend something different if it wants to compete on that same issue. This assumption is consistent with the sequential play analyzed in this paper.

Assumption 1: Suppose that one party has proposed alternative $a_i \in A_i$ on issue i , then the other party cannot win by proposing the same alternative. That is, $\pi_i(a_i, a_i) = 0$ for the last party proposing alternative a_i .

2.3. Issue salience and policy consensus

Each issue is characterized by some social or *pre-campaign salience*, which reflects voters' concerns, and by some *consensus* on the best policy.

The preferences of voters regarding which issues should be more important in the election can be formed through personal experiences, media emphases, interest groups' promotions or uncontrolled events. But it seems logical that the degree of salience in voters' perception should be related to the degree of social discontent with the status-quo policy on the issue. In this sense, we measure the salience of issue i in an inverse relation to the agreement or consensus with the status-quo policy. High-salience implies that a large group of voters ($\mathbf{F}_i^x + \mathbf{F}_i^y$) disagree on the prevailing status-quo on the issue.

Definition 2. Define the (pre-campaign) *salience* of issue i as $\sigma_i = \mathbf{F}_i^x + \mathbf{F}_i^y$.

However, social discontent with the status-quo, and hence high salience, does not necessarily imply a broad consensus on the best policy alternative. It may be, on the contrary, that voters are highly divided on which alternative would be better than the status-quo. We adapt from an index originally proposed by Reynal-Querol (2002), which captures how far the distribution of support for the two alternative policy proposals is from the most polarized ($1/2, 1/2$) distribution, which represents the lowest level of consensus.

Definition 3. Define the degree of *policy consensus* on issue i as $\zeta_i = 1 - 4 \frac{\mathbf{F}_i^x \mathbf{F}_i^y}{\mathbf{F}_i^x + \mathbf{F}_i^y}$.

Policy consensus has a range of values values between 0 and 1. Given an issue with pre-campaign salience $\sigma_i = \mathbf{F}_i^x + \mathbf{F}_i^y$ we can write

$$\zeta_i = 1 - 4 \frac{\mathbf{F}_i^x (\sigma_i - \mathbf{F}_i^x)}{\sigma_i} \quad (2)$$

Therefore, the maximum value of consensus ζ_i is 1, when there is total consensus on the best alternative to the status-quo (i.e. $\mathbf{F}_i^x = \sigma_i$ and so $\mathbf{F}_i^y = 0$), and the minimum value of ζ_i is 0, when the discontented electorate is evenly split between the alternatives x_i and y_i (i.e. $\mathbf{F}_i^x = \mathbf{F}_i^y = \sigma_i/2$).

Proposition 1. Let σ_i and ζ_i be, respectively, the pre-campaign salience and the degree of policy consensus on issue i . Then

$$\frac{\sigma_i}{2} < \zeta_i \leq 1. \quad (3)$$

Proof: See Appendix

##

Figure 1 describes the set of feasible pairs of issue salience and policy consensus. All of them are located on the upper right side of the diagonal to reflect the just presented fact that the degree of consensus on a policy alternative is always higher than half the discontented electorate with the status-quo or ‘issue salience’.

There are, however, several segments within this area which must be identified. First, the triangle ABE captures all those issues which take relatively low salience among voters’ as pre-campaign concerns ($\sigma_i < 1/2$) thus implying relatively high support for the status-quo policies on the issues ($1 - \mathbf{F}_i^x - \mathbf{F}_i^y > 1/2$), although there is relatively high consensus on a policy alternative among the few discontented voters. Given the low salience of these issues it is unlikely than any of them will be chosen in priority by any of the parties in the electoral campaign.

Second, the area BDE includes all those issues with relatively high salience ($\sigma_i > 1/2$), but relatively low consensus on an alternative policy to the status-quo. The area is defined by the line $\zeta_i = \frac{1 - \sigma_i}{\sigma_i}$ which expresses that the probability to defeat the status-quo is exactly 1/2. On the left of this line, $\zeta_i < \frac{1 - \sigma_i}{\sigma_i}$, so that, for any policy alternative to the status-quo, the probability of victory is less than 1/2.

Finally, the larger area in the upper-right corner BCD encompasses all those issues which take relatively high salience ($\sigma_i > 1/2$) and on which a policy alternative to the status-quo obtains relatively broad consensus ($\zeta_i > \frac{1 - \sigma_i}{\sigma_i}$). This area corresponds to the set of likely successful issues.

Proposition 2. An issue i exhibits $\pi_i^x > 1/2$ if and only if $\sigma_i > 1/2$ and $\zeta_i > \frac{1-\sigma_i}{\sigma_i}$.

Proof: See Appendix

##

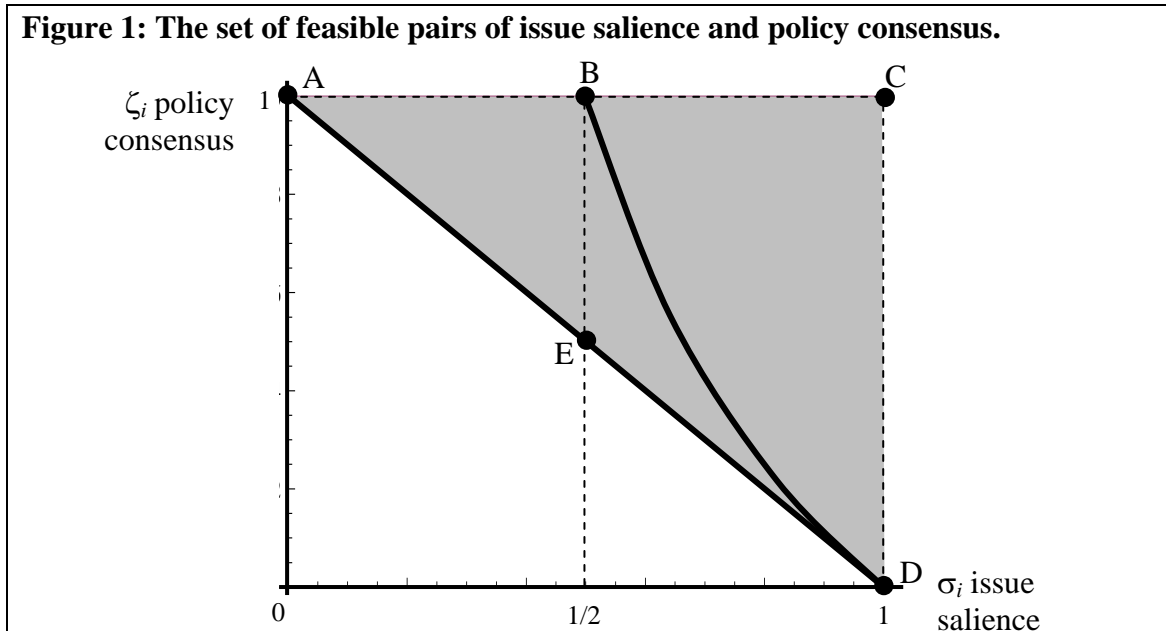

2.4. Post-campaign or political salience

In order to make an issue decisive in the election, parties try to make it ‘salient’ in voters’ decision by giving it political salience. Parties confer political salience by campaigning on the issue and proposing a policy alternative to the status-quo. Let us call the political salience or *post-campaign salience* of issue k the probability that k becomes the decisive issue once parties have campaigned on issues i and j .

Definition 4. Define the *post-campaign salience* or *political salience* of issue k when parties have politicized issues i and j , $s_{ij}(k)$, as the probability that issue k becomes the decisive issue.

We impose the following assumptions on the measure of political salience. First, parties can give political salience to an issue only by proposing a policy alternative to the status-quo. This implies that issues not raised in the electoral campaign do not get salience and hence cannot be decisive. Secondly, if both parties decide to campaign on the same issue, then it becomes the decisive issue since it is the only issue raised during the electoral campaign. Finally, if parties give political salience to two different issues, the probability for each issue to become decisive equals its relative salience.

Assumption 2. Given a pair of issues, i, j , chosen by the government and the opposition parties:

1. $s_{ij}(k) = 0$ for all $k \notin \{i, j\}$,
2. $s_{ii}(i) = 1$, for all $i = 1, \dots, N$
3. $s_{ij}(i) = \frac{\sigma_i}{\sigma_i + \sigma_j}$ for all $i \neq j$

It follows that for any pair of different issues, $s_{ij}(i) = 1 - s_{ij}(j)$. We will write $s_{ij} = s_{ij}(i)$ whenever there is no ambiguity.

2.5 The expected probability of electoral victory

Parties want to win the election. Observe that parties face uncertainty on the identity of the decisive issue as well as on the winning position on each issue. When parties compete on the same issue, this issue becomes decisive and their probability of victory coincides with their probability of holding the winning policy position on that issue. When parties campaign on different issues, the probability of victory is the expected probability of holding the winning policy position on the decisive issue.

Definition 5. Define the *expected probability of victory* Π for a party proposing alternative a_i on issue i , while the other party proposes alternative a'_j on issue j as

$$\Pi(a_i, a'_j) = \begin{cases} \pi_i(a_i, a'_j) & \text{if } j = i \\ s_{ij} \pi_i(a_i, q_i) + (1 - s_{ij})(1 - \pi_j(a'_j, q_j)) & \text{if } i \neq j \end{cases} \quad (4)$$

Observe that the definition presumes that voters associate the position of a party not proposing a policy alternative on an issue to the status quo.

2.6. Timing and equilibrium

The political game consists of choosing policy issues and alternatives to compete on for the next election. It develops sequentially. (See Figure 2.) First, the government party may choose either taking the initiative and not waiting (nw) or waiting (w). Taking the initiative means that the government party chooses one issue i on which it proposes a policy alternative to the status-quo $a_i \in A_i$, $a_i \neq q_i$. Then the opposition party can fight the government party's proposal either by defending the status quo q_i , by defending the other alternative on the issue, or by devoting its efforts to raising another issue j on which to propose a policy alternative $a'_j \neq q_j$, $j \neq i$.⁶ If, on the contrary, the government chooses waiting, the opposition can choose one issue c on which to propose a policy alternative to the status-quo $b_c \in A_c$, $b_c \neq q_c$. Then the government party can either compete on the issue or raise a new issue k ($b'_k \neq q_k$, $k \neq c$).

⁶ Observe that proposing the same alternative a_i or a status-quo on a different issue q_j , $j \neq i$, as they are strictly dominated strategies yielding zero probability of victory.

Figure 2. Game Tree showing the timing of the game.

The final nodes represent the issues raised during the electoral campaign and the expected probabilities of victory for the incumbent government (G).

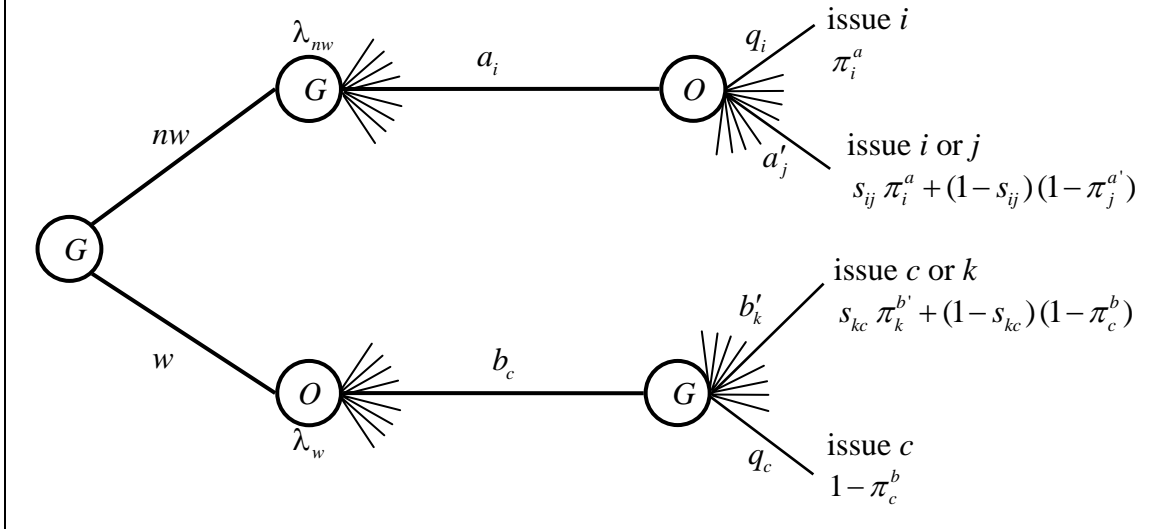

3. Equilibrium results

We focus the analysis on subgame perfect equilibria, the standard concept in sequential games with complete information. Such equilibria are characterized by:

- 1) the government choosing:
 - (i) either taking the initiative or waiting,
 - (ii) a policy alternative on one issue in case of taking the initiative,
 - (iii) and a strategy in response to each possible policy alternative proposed by the opposition;

and by

- 2) an opposition choosing:
 - (i) a strategy in response to each policy alternative proposed by the government in case it takes the initiative, and
 - (ii) a policy alternative on one issue to propose in case the incumbent government does wait.

The strategies must be optimal responses in each subgame. Because this is a finite, zero-sum game, a subgame perfect equilibrium always exists and parties will have the same probabilities of victory in all equilibria.

We follow standard backward induction. We start by finding the optimal actions of the players at each final decision node and continue working back to the beginning of the game.

3.1. Subgames Γ_w and Γ_{nw}

Let Γ_w and Γ_{nw} be the two proper subgames following the incumbent's choice of taking the initiative or waiting. (Their initial nodes are labeled as λ_{nw} and λ_w in Figure 2.) These two subgames are symmetric, and hence it suffices to analyze only one of them. Denote the first mover of each subgame (G in Γ_{nw} and O in Γ_w) as player 1, and the second mover as player 2. The following proposition and its corollary characterize the best response correspondence for player 2.

Proposition 3. *Let $BR(x_i)$ be the set of best responses of player 2 to the proposal x_i by player 1. Then*

1. $q_i \in BR(x_i)$ if and only if $1 - \pi_i^x \geq \max_{k \neq i} \pi_k^x$.
2. $x_j \in BR(x_i)$ if and only if $1 - \pi_i^x \leq \pi_j^x$, and

$$\left(\pi_j^x - (1 - \pi_i^x)\right) s_{ji} \geq \left(\pi_k^x - (1 - \pi_i^x)\right) s_{ki} \text{ for all } k \neq i, j.$$

Proof: See Appendix.

##

An implication of Proposition 3 is that the best response is independent of the pre-campaign salience σ_i , and thus of the degree of social discontent with the status-quo

policy, whether the best response is defending the status quo or raising a new issue. This result will also hold in the full game, as discussed below.

Corollary 1. *Consider the policy proposal $x_i \in A_i$.*

1. *If $i > 1$, then*

$$BR(x_i) = \begin{cases} q_i & \text{if } \pi_i^x < 1 - \pi_1^x, \\ \{q_i, x_1\} & \text{if } \pi_i^x = 1 - \pi_1^x, \\ \arg \max_{x_k \neq x_i} \Pi(x_i, x_k) & \text{if } \pi_i^x > 1 - \pi_1^x. \end{cases} \quad (5)$$

2. *For $i = 1$,*

$$BR(x_1) = \begin{cases} q_1 & \text{if } \pi_2^x < 1 - \pi_1^x, \\ \{q_1, x_2\} & \text{if } \pi_2^x = 1 - \pi_1^x, \\ \arg \max_{x_k \neq x_1} \Pi(x_k, x_1) & \text{if } \pi_2^x > 1 - \pi_1^x. \end{cases} \quad (6)$$

Proof: See Appendix.

##

3.2. The full game

Consider the full game where the incumbent party may either take the initiative and propose a policy alternative on some issue (and hence play the subgame Γ_{nw}), or hold to the current situation and wait for the challenger to propose some alternative (and play subgame Γ_w).

As the following theorem shows, the *equilibrium* depends only on the two issues with the highest probabilities of victory. Whether parties compete on the same issue or raise different issues is independent of the pre-campaign issue salience, which reflects voters' concerns.

Theorem 1. *Consider an agenda-setting political competition game.*

1. *If $\pi_1^x \leq 1/2$ or $\pi_1^x \geq 1 - \pi_1^x > \pi_2^x$, then both parties compete on the same issue.*

2. If $\pi_1^x > \pi_2^x > 1 - \pi_1^x$, then parties focus on different issues.

Proof: See Appendix.

##

The intuition is not difficult to grasp. If there is not a *good* (likely successful) issue on which to propose a new policy alternative ($\pi_1^x \leq 1/2$), then, at equilibrium, the government waits and defends the status-quo on all issues. If there is a single best-alternative which is better than defending the status-quo and much better than any other alternative ($\pi_1^x \geq 1 - \pi_1^x > \pi_2^x$), then the government takes the initiative and proposes that policy alternative, while the opposition is forced to defend the status-quo on the issue. Finally, if there are promising policy alternatives on two issues ($\pi_1^x > \pi_2^x > 1 - \pi_1^x$), the two parties raise different issues.

Equilibrium results can be presented in terms of issue salience and policy consensus.

Theorem 2. *Consider an agenda-setting electoral competition game in which parties choose issues to be raised during the electoral campaign; σ_i is the degree of issue salience and ζ_i is the degree of consensus on a policy alternative to the status quo on issues i .*

1. Let $\sigma_1 < 1/2$, then both parties focus on the same issue.

The degree of issue salience is low (all the issues are within the triangle ABE in the Figure 1). The government defends the status-quo on all issues and the opposition chooses the best issue to challenge the status-quo. They may not choose the most salient issue.

2. Let $\sigma_1 > 1/2$, but $\zeta_1 < \frac{1 - \sigma_1}{\sigma_1}$, then both parties focus on the same issue.

Some issue takes high salience among voters, but there is no broad

consensus on the best policy alternative to the status quo on the issue (all the issues are within the set ABD in Figure 1, with some in BDE), the opposition chooses the issue on which a policy alternative has the highest support, and the government defends the status-quo on all issues. They may not choose the most salient issue.

3. Let $\sigma_1 > 1/2$ and $\zeta_1 > \frac{1-\sigma_1}{\sigma_1}$, then the government chooses an issue with

high salience and broad policy consensus.

If there exists another issue with sufficient salience and consensus on the best policy alternative to the status-quo, the opposition chooses that issue and parties focus on different issues. The most salient issue may not be chosen. Otherwise the government proposes the best policy on the most salient issue and the opposition defends the status-quo on that issue.

These results show that the incumbent government can benefit from a higher probability of winning and always chooses an issue with relatively high salience and broad consensus (within the set BCD in Figure 1), if there is any.

Corollary 2. Let $\rho = \max_i \min_{j \neq i} \Pi_G(x_i, x_j)$. The incumbent government wins with probability $\max\{\rho, 1-\rho\} > 1/2$.

Proof: See Appendix.

##

Proposition 4. Suppose there exists at least one issue i with $\sigma_i > 1/2$ and $\zeta_i > \frac{1-\sigma_i}{\sigma_i}$,

then the issue chosen by the government at equilibrium exhibits both high salience and

broad policy consensus, $\sigma_G > 1/2$ and $\zeta_G > \frac{1-\sigma_G}{\sigma_G}$.

Proof: See Appendix.

##

However, it is interesting to note that we cannot extend this latest result to the opposition, which may have to choose an issue with low salience or low consensus.

Example. Consider an election in which three potential issues have the following distribution of support among the electorate:

$$(\mathbf{F}_1^x, \mathbf{F}_1^y) = (0.6, 0.35); (\mathbf{F}_2^x, \mathbf{F}_2^y) = (0.51, 0.04); (\mathbf{F}_3^x, \mathbf{F}_3^y) = (0.49, 0.41),$$

which corresponds to the following salience and consensus values:

$$(\sigma_1, \zeta_1) = (0.95, 0.116); (\sigma_2, \zeta_2) = (0.55, 0.852); (\sigma_3, \zeta_3) = (0.9, 0.107).$$

By Proposition 4 the government will not choose issue 3 because the degree of policy consensus is low: $\zeta_3 < \frac{1-\sigma_3}{\sigma_3} = 0.11$. In fact, the incumbent government will take

the initiative and choose issue 1, which is more salient and has broader consensus than issue 2. However, for the opposition to choose an issue, it is relevant to see that on issue 2 there is broader policy consensus than on issue 3, but issue 2 is much less salient. In this case, the trade-off is favorable to issue 3, in spite of having low consensus. At equilibrium, the opposition does not choose issue 2, which has both high salience and broad consensus, $\sigma_2 > 1/2$ and $\zeta_2 > \frac{1-\sigma_2}{\sigma_2} = 0.82$, but chooses x_3 instead.⁷ Hence

Proposition 5 does not apply to the opposition party.

Proposition 5 also shows that the only situation in which we can guarantee that

⁷ For all the examples we take $\pi_i^x = \mathbf{F}_i^x$ and $\pi_i^y = \mathbf{F}_i^y$, and compute equilibria using *Mathematica*. The program code can be obtained from the authors by request.

the most salient issue is brought up during the electoral campaign is when there is high consensus on the best alternative in this issue and all the other issue show very low salience.

4. Examples

We provide a few numerical examples to illustrate how parties competing in setting the electoral agenda can overlook the concerns of the electorate, as represented by issue salience, by choosing either to defend an unpopular status-quo on the issue or not talking about it at all.

4.1. Neither the most salient nor the most consensual issues are chosen

Consider an election with four potential issues whose distribution of support among the electorate is represented by

$$(\mathbf{F}_1^x, \mathbf{F}_1^y) = (0.6, 0.35); (\mathbf{F}_2^x, \mathbf{F}_2^y) = (0.51, 0.04); (\mathbf{F}_3^x, \mathbf{F}_3^y) = (0.49, 0.41),$$

which corresponds to the following salience and consensus values:

$$(\sigma_1, \zeta_1) = (0.65, 1); (\sigma_2, \zeta_2) = (0.55, 0.852); (\sigma_3, \zeta_3) = (0.9, 0.107),$$

as represented in Figure 3.

In equilibrium, government and opposition focus on different issues, 2 and 3 respectively. Specifically, the government takes the initiative and announces x_2 and the opposition responds by choosing x_3 . Both parties overlook issue 4, which is the most salient issue (90% of the electorate are *against* the status-quo), and issue 1, which is the one with highest consensus (everybody in favor of changing the status-quo agrees on the alternative policy). Nevertheless, they focus on issues with either higher consensus than issue 4 or more salience than issue 1.

Figure 3.
Example 1: Neither the most salient nor the most consensual issues are chosen

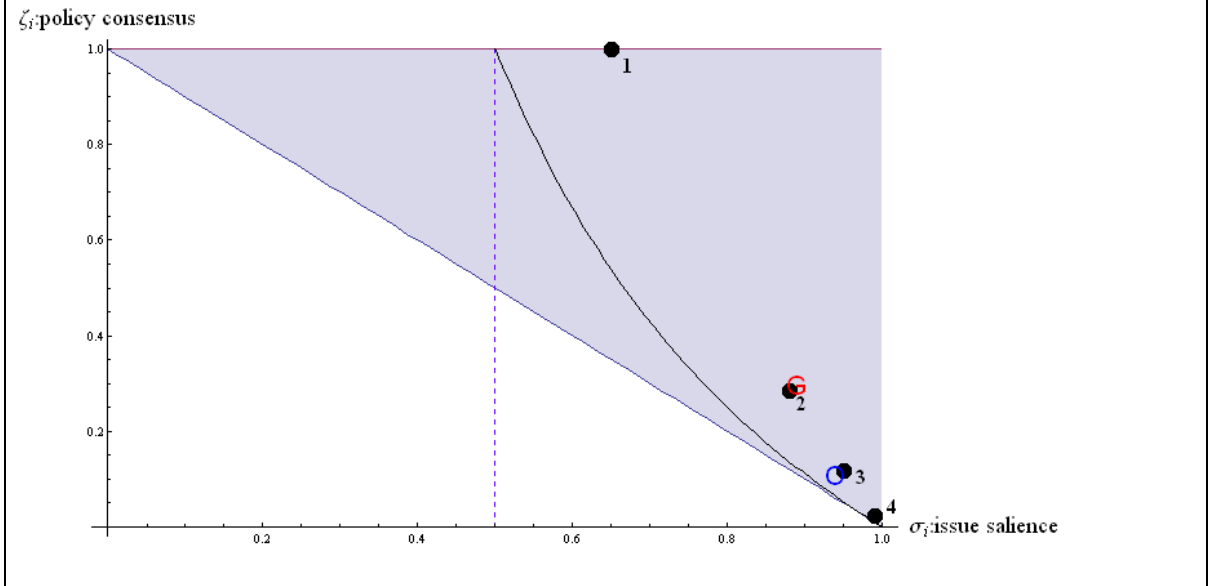

4.2. Parties may focus on the least salient issue

Consider an election in which three potential issues have the following distribution of support among the electorate

$$(\mathbf{F}_1^x, \mathbf{F}_1^y) = (0.51, 0.01); (\mathbf{F}_2^x, \mathbf{F}_2^y) = (0.44, 0.40); (\mathbf{F}_3^x, \mathbf{F}_3^y) = (0.40, 0.39),$$

which corresponds to the following salience and consensus values:

$$(\sigma_1, \zeta_1) = (0.52, 0.96); (\sigma_2, \zeta_2) = (0.84, 0.162); (\sigma_3, \zeta_3) = (0.79, 0.21),$$

as represented in Figure 4.

The government chooses issue 1, the only one in BCD (recall Proposition 4). The opposition does not choose issues 2 or 3 for lack of consensus on the best policy on those issues, but it rather challenges the government on the same issue 1. The electoral campaign focuses on the least salient issue. If the issue chosen by the government, 1, benefited from significantly broader policy consensus and were, thus, a more secure

issue, the opposition would choose another issue (issue 2 in the example).

In this case, the opposition does not challenge the highly unsatisfactory status-quo policies on issues 2 and 3 (with around 80% of electorate in favor of changing the status-quo) as they lack voters' consensus on the best alternative.

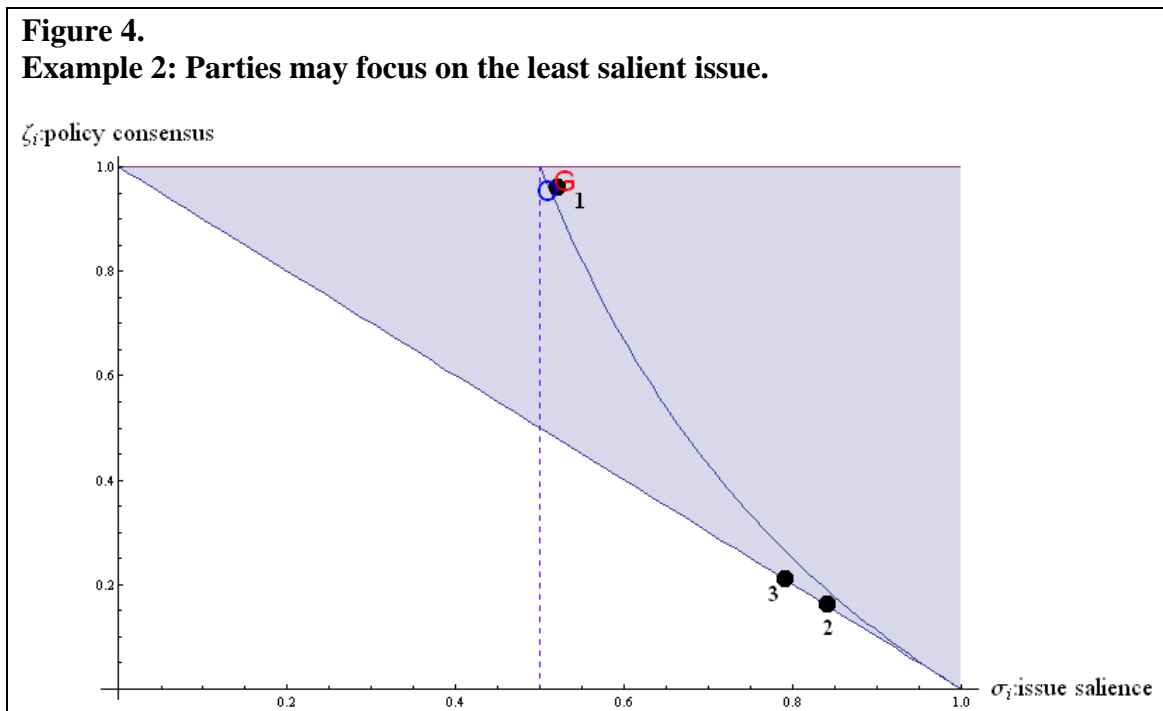

These are just specific examples to show possible occurrences. To approach more general results, we can note that parties will never choose the issue with both the lowest salience and the highest controversy or lowest consensus on the appropriate policy alternative. But regarding highly salient issues, if there is not sufficiently broad consensus on a policy alternative, the opposition party may choose not to challenge a highly unsatisfactory status-quo policy and the incumbent government may survive in spite of its bad policy performance.

5. Illustration

Some features of the model could be illustrated with cases from the real world if the basic variables –pre-campaign issue *saliency* in voters’ concerns and *consensus* in favor of one of the policy alternatives on each issue– could be operationalized with data from survey polls and electoral campaigns. Just as an informal example to show the analytical potential of the model let us take the United States presidential election in 2004.

This case seems sufficiently close to our assumptions regarding a two party competition for a single office by plurality rule. Several survey polls asked voters to identify the most important issues in the 2004 U.S. presidential election. Observers broadly coincide in identifying ‘moral values’, ‘the economy’, ‘terrorism’, and ‘the Iraq war’, in this order, followed by others with minor impact such as ‘health care’, ‘taxes’, and ‘education’. High consensus was obtained (in favor of the alternatives promoted by the Republicans) on ‘terrorism’, ‘moral values’ and ‘taxes’, in this order, and (in favor of the alternatives promoted by the Democrats) on ‘the economy’, ‘health care’, ‘education’, and ‘the Iraq war’, also in this order. (See National Election Pool 2004, Stroud and Kenski 2007, as well as similar operationalizations for previous elections by RePass 1971, McCombs and Zhu 1995, Burden and Sanberg 2003, and discussion by Wlezien 2005).

Regarding the actual choice of issues during the electoral campaign by the two major candidates, Republican George W. Bush and Democrat John Kerry, there is also high coincidence in the academic literature. On the basis of people’s responses to the ‘most important issue’ question, Weisberg (2005) conjectured that “people who supported Bush naturally would have chosen terrorism as their top concern. Kerry argued that the Iraq war was a diversion from the fight against Al Qaeda, so his

supporters would likely have chosen Iraq as their first concern.” (p. 784). While indeed Democratic activists and opinion-makers pressured in favor of Kerry campaigning mainly about ‘Iraq’ in response to Bush’s emphasis on ‘terrorism’, polls show that most people agreed with the statement that the Iraq war was part of the war on terrorism (as observed by Norpoth and Sidman 2007).

However, while Bush indeed chose ‘terrorism’ as the first issue, Kerry did not focus on ‘Iraq’, but on ‘the economy’. “George W. Bush ran for re-election as a war-time president, emphasizing the importance of staying the course on the ‘War on Terrorism’. At the same time, the economy had not fully recovered from the recession, and the job picture remained lackluster; his opponent, John Kerry, stressed the economy and other domestic issues such as health care” (Weisberg 2005, p. 777; see also Weisberg and Christenson 2007).

Other empirical analyses confirm the basic traits just remarked. According to Abramson, Aldrich and Rohde (2005), vote decisions were based largely upon retrospective evaluation of Bush as a successful president and as a leader who would be successful in combating terrorism, while moral values and social issues had low importance. In a close analysis, it is noted that as the threat of terrorism remained a substantial concern through election day and afforded Bush an overwhelming advantage, although the state of the economy and the war in Iraq were viewed negatively by most voters (Abramson, Aldrich, Rickershauser and Rohde 2007). In another stance by Campbell (2005), it is remarked that the influence of the campaign was affected by major concerns that Kerry would not handle the war on terrorism as well as Bush, while there were more divided views about the economy and Iraq.

We can observe that none of the candidates chose to campaign in priority for the issue which could have higher pre-campaign salience among voters, ‘moral values’. Numerous observers noted that, in spite of pundits’ comments, ‘moral values’ ranked

low in the issues list predicting actual voters' choices at the end of the electoral campaign (for instance, Langer and Cohen 2005). Republican candidate George W. Bush, instead of choosing this issue, on which he obtained relatively high consensus and advantage regarding the other candidate, chose the one in which his policy had the highest consensus, even if it was considered less important by the voters, 'terrorism'. Democrat candidate John Kerry did not choose in priority the issue 'Iraq', which, as mentioned, would have been a direct response to the initiative in favor of 'terrorism' taken by Bush, apparently for lack of consensus on the best alternative policy. He instead chose the issue in which he could obtain the highest consensus, 'economy/jobs'. Both candidates gave, thus, priority to those issues in which they could expect more favorable consensus among the voters and higher advantage regarding the other candidate, rather than those which were more salient in voters' concerns.

6. Conclusion

We have presented an agenda-setting model of electoral competition in which parties choose to give salience and campaign on those issues on which they expect their policy proposals will obtain voters' broad support.

Parties have to trade off the pre-campaign salience of each issue in voters' concerns and the voters' support or consensus in favor of the policy alternatives on the issue. We have found that, although parties will not compete on irrelevant issues (those with both low salience among voters and divisive policy proposals), indeed the issues which are considered the most important ones by a majority of votes may not be given salience during the electoral campaign.

This may be a surprising result, as remarked at the beginning of this paper, but it may be a reasonable one after all. Even if there is extensive public concern on some

issue, if there is not a single policy proposal on the issue which can attract broad consensus, focusing on that issue might produce high division and polarization among both parties and voters. Important issues in people's concerns can, thus, be solved through electoral competition only when a policy alternative appears as clearly superior to voters' eyes. In the absence of a likely successful policy alternative, parties can choose not to give salience to the issue, thus maintaining the status-quo policy even if it is unsatisfactory for voters.

In the short term, mediocre policies broadly rejected by the electorate, as well as incumbent parties with no good performance in government, may survive for lack of a sufficiently convincing alternative. Since parties tend to choose to campaign on issues on the basis of relatively consensual policies, in the long term broad policy consensus can be accumulated on an increasing number of issues. But since parties do not always choose to campaign on the issues with the highest pre-electoral salience, the political agenda may successively select, address and settle policy issues in an order which may not correspond to their importance in voters' concerns.

7. References

- Abramson, P. R., J. H. Aldrich, and D. W. Rohde. 2005. 'The 2004 presidential election: The emergence of a permanent majority?', *Political Science Quarterly*, 120, 1: 33-57.
- Abramson, P. R., J. H. Aldrich, J. Rickershauser, and D. W. Rohde. 2007. 'Fear in the voting booth: The 2004 presidential election', *Political Behavior*, 29, 2: 197-220.
- Burden, B.C., and J.N.R. Sanberg, 2003. 'Budget rhetoric in presidential campaigns from 1952 to 2000', *Political Behavior*, 25: 97-118.
- Budge, I. 1993. 'Issues, dimensions, and agenda change in postwar democracies: Long-term trends in party election programs and newspaper reports in twenty-three democracies', in W.H. Riker ed. *Agenda Formation*, Ann Arbor: University of Michigan Press, pp. 41–80.
- Budge, I., H-D. Klingemann, A. Volkens, J. Bara and E. Tanenbaum. 2001. *Mapping policy preferences: Estimates for parties, electors, and governments 1945–1998*. Oxford and New York: Oxford University Press.
- Campbell, J. E. 2005. 'Why Bush won the presidential election of 2004: Incumbency, ideology, terrorism, and turnout', *Political Science Quarterly*, 120, 2: 219-242.
- Colomer, J. M., and R. Puglisi. 2005. 'Cleavages, issues, and parties: A critical overview of the literature', *European Political Science*, 4. 502-520.
- Klingemann, H.-D., A. Volkens, J. Bara, and I. Budge. 2006. *Mapping policy preferences II: Estimates for parties, electors and governments in Central and Eastern Europe, European Union and OECD 1990-2003*. Oxford and New York: Oxford University Press.
- Langer, G., and J. Cohen. 2005. 'Votes and values in the 2004 election', *Public Opinion*

Quarterly, 69, 5: 744-759.

McCombs, M., and J.-H., Zhu. 1995. 'Capacity, diversity, and volatility of the public agenda: trends from 1954 to 1994', *Public Opinion Quarterly*, 59: 495-525.

National Election Pool. 2004. Exit Poll for ABC-AP-CBS-CNN-Fox News-NBC News. Edison Media Research & Mitofsky International, provided by Voter News Service VNS and available at <http://edition.cnn.com/ELECTION/2004/pages/results/states/US/P/00/epolls.0.html>

Norpoth, H., and A. H. Sidman. 2007. 'Mission accomplished: The wartime election of 2004', *Political Behavior*, 29, 2: 175-195.

Petrocik, J.R. 1996. 'Issue ownership in presidential elections, with a 1980 case study', *American Journal of Political Science*, 40, 3: 825-850.

Petrocik, J.R., W.L. Benoit, and G. Hansen. 2002. 'Issue ownership and presidential campaigning, 1952-2000', *Political Science Quarterly*, 118, 4: 599-626.

Polborn, M.K. and S. Krasa. 2007. 'The Binary Policy Model'. Available at: <http://works.bepress.com/polborn/12>.

Reynal-Querol, Marta. 2002. 'Ethnicity, Political Systems, and Civil Wars', *Journal of Conflict Resolution*, 46, 1: 29-54.

Riker W.H. ed. 1993. *Agenda Formation*, Ann Arbor: University of Michigan Press.

Stokes, D.E. 1963. 'Spatial models of party competition', *American Political Science Review*, 57, 2: 368-377.

RePass, D.E. 1971. 'Issue salience and party choice', *American Political Science Review*, 65: 389-400.

Stroud, N. J., and K. Kenski. 2007. 'From agenda setting to refusal setting', *Public Opinion Quarterly*, 71, 4: 539-559.

Weisberg, H. F. 2005. 'The US presidential and congressional elections, November 2004', *Electoral Studies*, 24: 741-784.

Weisberg, H. F., and D. P. Christenson. 2007. 'Changing horses in wartime? The 2004 presidential election', *Political Behavior*, 29, 2: 279-304.

Wlezien, C. 2005. 'On the salience of political issues: The problem with 'most important problem'', *Electoral Studies*, 24: 555-579.

Appendix: Proofs

Proof of Proposition 1

Because $\sigma_i = \mathbf{F}_i^x + \mathbf{F}_i^y$ and $\mathbf{F}_i^x > \mathbf{F}_i^y \geq 0$, then $\mathbf{F}_i^x \in \left(\frac{\sigma_i}{2}, \sigma_i\right]$. We can write

$$\zeta_i = 1 - 4 \frac{\mathbf{F}_i^x (\sigma_i - \mathbf{F}_i^x)}{\sigma_i} \quad (\text{see (2)}). \text{ Hence, for a given level of salience } \sigma_i, \zeta_i \text{ is increasing in } \mathbf{F}_i^x$$

$$\left(\frac{\partial \zeta_i}{\partial \mathbf{F}_i^x} = -4 + 8 \frac{\mathbf{F}_i^x}{\sigma_i} > 0 \right). \text{ Therefore, } \zeta_i^x \in (1 - \sigma_i, 1].$$

##

Proof of Proposition 2

Because $\pi_i^x = \phi(\mathbf{F}_i^x)$ with $\phi' > 0$ and $\phi(1/2) = 1/2$, it suffices to show that $\mathbf{F}_i^x > 1/2$ if and only if $\sigma_i > 1/2$ and $\zeta_i > \frac{1 - \sigma_i}{\sigma_i}$.

i. Let $\mathbf{F}_i^x > 1/2$. Then $\sigma_i > 1/2$ (Definition 2). Because ζ_i is increasing in \mathbf{F}_i^x

$$\zeta_i > 1 - 4 \frac{1/2(1 - \sigma_i)}{\sigma_i} = \frac{1 - \sigma_i}{\sigma_i}, \text{ where we have substituted } \mathbf{F}_i^x = 1/2 \text{ in (2).}$$

ii. Let $\sigma_i > 1/2$. From (2), we can obtain $\mathbf{F}_i^x = \frac{\sigma_i + \sqrt{\sigma_i^2 - \sigma_i(1 - \zeta_i)}}{2}$. Hence, $\mathbf{F}_i^x > 1/2$ if

and only $\sigma_i + \sqrt{\sigma_i^2 - \sigma_i(1 - \zeta_i)} > 1$. After some manipulation, this is equivalent to

$$\zeta_i > \frac{1 - \sigma_i}{\sigma_i}. \text{ Therefore, if } \sigma_i > 1/2 \text{ and } \zeta_i > \frac{1 - \sigma_i}{\sigma_i}, \text{ then } \mathbf{F}_i^x > 1/2.$$

##

Proof of Proposition 3

1. We know that $q_i \in BR(x_i)$ if and only if $\Pi_2(q_i, x_i) \geq \Pi_2(x_k, x_i)$ for all $k \neq i$. That is, if and only if

$$1 - \pi_i^x \geq s_{ki} \pi_k^x + (1 - s_{ki})(1 - \pi_i^x) \text{ for all } j \neq k.$$

Since $s_{ki} \in (0, 1)$, the inequality holds if and only if $1 - \pi_i^x \geq \pi_k^x \forall k \neq i$, which is equivalent to the condition in the statement: $1 - \pi_i^x \geq \max_{k \neq i} \pi_k^x$.

2. Similarly, $x_j \in BR(x_i)$ if and only if it is better than choosing the status-quo in i

$\left(\Pi_2(x_j, x_i) \geq \Pi_2(q_i, x_i)\right)$ and better than choosing a policy alternative in another issue

$k \neq i, j$ $\left(\Pi_2(x_j, x_i) \geq \Pi_2(x_k, x_i)\right)$. The first condition is equivalent to

$s_{ji} \pi_j^x + (1 - s_{ji})(1 - \pi_i^x) \geq 1 - \pi_i^x$, that is, $\pi_j^x \geq 1 - \pi_i^x$. The second condition implies that for all

$k \neq i, j$, $s_{ji} \pi_j^x + (1 - s_{ji})(1 - \pi_i^x) \geq s_{ki} \pi_k^x + (1 - s_{ki})(1 - \pi_i^x)$. Simplifying,

$$\left(\pi_j^x - (1 - \pi_i^x)\right) s_{ji} \geq \left(\pi_k^x - (1 - \pi_i^x)\right) s_{ki}.$$

##

Proof of Corollary 1

Recall that $\pi_1^x > \pi_2^x > \pi_i^x$ for all $i > 2$. Observe that

$$\Pi(x_j, x_i) = s_{ji}\pi_j^x + (1-s_{ji})(1-\pi_i^x) = (1-\pi_i^x) + s_{ji}(\pi_j^x - (1-\pi_i^x)).$$

Hence, maximizing $\Pi(x_j, x_i)$ with respect to x_j for a given x_i is equivalent to maximizing $s_{ji}(\pi_j^x - (1-\pi_i^x))$ —the expression in part 2 of Proposition 3. Therefore, the results follow directly from Proposition 3. ##

Proof of Theorem 1

We proceed case by case.

1. Let $\pi_1^x \leq 1/2$. Then $\pi_i^x < \pi_1^x \leq \frac{1}{2} \leq 1-\pi_1^x \quad \forall i > 1$. It follows from Corollary 1 that $BR(x_k) = q_k$

for all issue k , implying that both parties compete on the same issue.

2. Let $\pi_1^x \geq 1-\pi_1^x > \pi_2^x$. Then $1-\pi_1^x > \pi_i^x$ for all $i > 1$. From Corollary 1, $BR(x_i) = q_i$ for all i , and hence both parties compete on the same issue.

3. Let $\pi_1^x > \pi_2^x > 1-\pi_1^x$. Let (a_1^*, a_2^*) be the policy alternatives of an equilibrium outcome.

We only need to show that $a_2^* = x_i$ for some i and hence parties give political salience to different issues.

Suppose that, on the contrary, $a_2^* = q_k$ for some k . Then $(a_1^*, a_2^*) = (x_k, q_k)$ and player 1 wins with probability $\Pi(x_k, q_k) = \pi_k^x$. From Corollary 1, it must be that $\pi_k^x \leq 1-\pi_1^x$. By definition,

$$\Pi(x_1, BR(x_1)) = \min_{i>1} \{s_{1i}\pi_1^x + (1-s_{1i})(1-\pi_i^x)\} > 1-\pi_1^x,$$

since $\pi_1^x > 1-\pi_1^x \geq 1-\pi_i^x$. But then $\Pi(x_1, BR(x_1)) > 1-\pi_1^x \geq \pi_k^x$, and so x_1 is a better choice than x_k for player 1, a contradiction with (x_k, q_k) being the equilibrium policies. Therefore, it cannot be that $a_2^* = q_k$ and parties must give political salience to different issues. ##

Proof of Theorem 2

1. Let $\sigma_1 < 1/2$, then $\pi_1^x < 1/2$ (Proposition 2). From Theorem 1, both parties focus on the same issue. At the subgame Γ_s ($s = w, nw$) player 2 always responds by defending the status-quo, hence player 1 chooses issue 1, the one with the highest probability of victory, and player 2 defends the status-quo q_i against any alternative x_i . Player 1 wins with probability π_1^x . When deciding whether to take the initiative or wait, the government compares

$\Pi_G(\Gamma_w) = 1-\pi_1^x \geq \pi_1^x = \Pi_G(\Gamma_{nw})$ and chooses to wait, where (abusing notation) $\Pi_G(\Gamma_s)$ represents the incumbent government's expected probability of victory associated to any Nash Equilibrium of the subgame Γ_s . Therefore, at the equilibrium path of the full game the opposition chooses x_1 while the incumbent government defends the status-quo in all issues.

Consider the following example with issues $(\mathbf{F}_1^x, \mathbf{F}_1^y) = (0.3, 0.1)$, $(\mathbf{F}_2^x, \mathbf{F}_2^y) = (0.25, 0.2)$ and

$\mathbf{F}_i^x < \mathbf{F}_2^x$ for all $i > 2$. Observe that $\frac{1}{2} > \pi_1^x > \pi_2^x > \pi_i^x$ for all $i > 2$ since $\pi_j^x < \frac{1}{2}$ if and only if

$\mathbf{F}_j^x < \frac{1}{2}$. Hence, since both parties focus on issue 1 at equilibrium and $\sigma_2 = 0.42 > 0.4 = \sigma_1$,

they do not choose the most salient issue.

2. Let $\sigma_1 > 1/2$ and $\zeta_1 < \frac{1-\sigma_1}{\sigma_1}$. From Proposition 2, $\pi_1^x < 1/2$. Theorem 1 implies again that

both parties focus on the same issue. A similar argument as the one used in the previous case shows that the opposition chooses the issue 1 and the government waits and defends the status-quo.

Consider the following example. $(\mathbf{F}_1^x, \mathbf{F}_1^y) = (0.4, 0.2)$, $(\mathbf{F}_2^x, \mathbf{F}_2^y) = (0.35, 0.3)$ and $\mathbf{F}_i^x < \mathbf{F}_2^x$ for all $i > 2$. Observe that $\sigma_2 = 0.65 > 0.6 = \sigma_1 > 1/2$ and $\zeta_1 = 0.466 < 0.66 = \frac{1-\sigma_1}{\sigma_1}$. Hence, both parties choose issue 1, while issue 2 shows higher salience (although lower consensus).

3. Let $\sigma_1 > 1/2$ and $\zeta_1 > 1/2$. From Proposition 2 $\pi_1^x > \frac{1}{2}$. From and Theorem 1, if $\pi_2^x > 1 - \pi_1^x$ they focus on different issues, otherwise they choose the same issue. Let $k = \phi^{-1}(1 - \pi_1^x)$, that is the electoral support that an alternative x would need to defeat the status-quo with probability $1 - \pi_1^x$. Then, $\pi_2^x > 1 - \pi_1^x$ if and only if $\mathbf{F}_2^x > k$. But $\mathbf{F}_2^x > k$ if and only if $\sigma_2 > k$ and $\zeta_2 > 1 - 4 \frac{k(\sigma_2 - k)}{\sigma_2}$. First, by definition, $\sigma_2 > k$ is a necessary condition for $\mathbf{F}_2^x > k$.

Second, if $\sigma_2 > 2k$, then $\mathbf{F}_2^x > \frac{\sigma_2}{2} > k$. Finally, observe that $1 - 4 \frac{F(\sigma_2 - F)}{\sigma_2}$ is an increasing

function of F for any $F > \frac{\sigma_i}{2}$. Hence, if $2k > \sigma_2 > k$, $\zeta_2 = 1 - 4 \frac{\mathbf{F}_2^x(\sigma_2 - \mathbf{F}_2^x)}{\sigma_2} > 1 - 4 \frac{k(\sigma_2 - k)}{\sigma_2}$

if and only if $\mathbf{F}_2^x > k$. Therefore, if there exists another issue with enough salience and

consensus (namely $\sigma_2 > k$ and $\zeta_2 > 1 - 4 \frac{k(\sigma_2 - k)}{\sigma_2}$ where $k = \phi^{-1}(1 - \pi_1^x)$) parties focus on

different issues, otherwise they both compete on the same issue.

As the examples in sections 4.1 and 4.2 show, they may not choose the most salient, nor focus on issue 1 and 2.

##

Proof of Corollary 2

We know that $\rho = \max_i \min_j \Pi_1(x_i, x_j)$ and $1 - \rho$ are the values of the games Γ_{mw} and Γ_w , respectively, and that the incumbent government can choose the subgame to play by waiting or taking the initiative. Therefore, the government will choose the subgame with the highest value and hence its probability of winning will be $\max\{\rho, 1 - \rho\} \geq 1/2$.

##

Proof of Proposition 4.

1. By Proposition 2, we only need to show that if the incumbent government chooses the issue

G , then $\pi_G^x > \frac{1}{2}$. Assume that there exists an issue i such that $\sigma_i > \frac{1}{2}$ and $\zeta_i > \frac{1}{2}$.

Then, $\pi_i^x > \frac{1}{2}$ and hence $\pi_1^x > \frac{1}{2}$, as $\pi_1^x \geq \pi_i^x$ for all i .

2. Suppose that $\pi_G^x < \frac{1}{2}$.

i. Then $\pi_2^x > 1 - \pi_1^x$, otherwise the government could choose issue 1 at equilibrium and obtain $\Pi_G^* = \pi_1^x > \frac{1}{2}$.

ii. Because $\pi_2^x > 1 - \pi_1^x$ we know by Theorem 1 that parties choose different issues and, by Corollary 2, $\Pi_G^* > \frac{1}{2} > \Pi_O^*$.

iii. Moreover, it must be that $\pi_O^x < \frac{1}{2}$. Otherwise $\Pi_G^* = s_{GO} \pi_G^x + (1 - s_{GO})(1 - \pi_O^x) < \frac{1}{2}$, a contradiction with (ii).

iv. If the government does not wait (Γ_{nw}), it must be that

$$\Pi_O^* \geq s_{iG} \pi_i^x + (1 - s_{iG})(1 - \pi_G^x) \quad \text{for all } i \neq G.$$

Since $\Pi_O^* < \frac{1}{2}$ and $1 - \pi_G^x \geq \frac{1}{2}$, it follows that $\pi_i^x \leq \frac{1}{2}$ for all $i \neq G$. But this is a

contradiction with the initial assumption that $\pi_1^x > \frac{1}{2}$.

v. If the government waited at equilibrium, the opposition could always choose issue 1 and guarantee a probability of victory of at least $\underline{\Pi}$:

$$\underline{\Pi} = \min_{i \neq 1} s_{i1} \pi_1^x + (1 - s_{i1})(1 - \pi_i^x) \leq \Pi_O^*.$$

Because $\Pi_O^* < \frac{1}{2}$ and $\pi_1^x > \frac{1}{2}$, it follows that $\pi_i^x \geq \frac{1}{2}$ for all i . But this is a

contradiction with the government choosing an issue with $\pi_G^x < \frac{1}{2}$.

Therefore we have proved that at equilibrium $\pi_G^x > \frac{1}{2}$ and so (by Proposition 2) $\sigma_G > \frac{1}{2}$ and

$$\zeta_G > \frac{1}{2}.$$

##